

INSTALLATION MANUAL
FOR
Universal Quick Release Laptop Stand

IMPORTANT INFORMATION:

The photos and illustrations contained in this manual are (only) to be used as a guide and as an example to help aid the installer to visualize an installation. All vehicles are configured differently around the seat base.

mobotron™
Universal Quick Release
Laptop Stand
LTM-MS-525



Thank you for purchasing your new Mobotron **Universal Quick Release Laptop Stand**

IMPORTANT INFORMATION

IMPORTANT INFORMATION

Note: This basic instruction ships with every LTM-MS-525 and is meant to be used as a general instruction guide. This guide will give you the basic understanding and concept of how to install the Mobotron Universal Quick Release Laptop Stand.

LAPTOP DECK ASSEMBLY AND POSITIONING

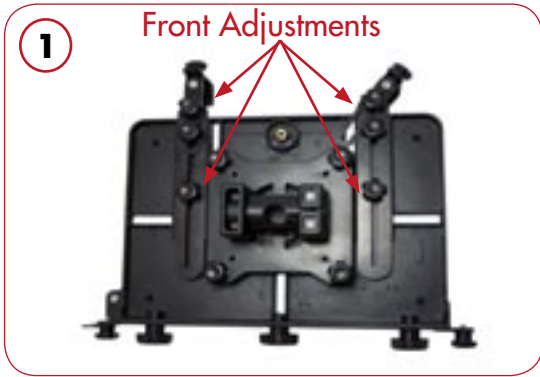

1 Start the assembly by setting up the base of the laptop deck. On the bottom of the deck you will notice all the different adjustments. Set your laptop in place so you will know where to adjust the front mounts too. **Note:** For a smaller laptop you may be able to keep the slots of the outside brackets under the knob.

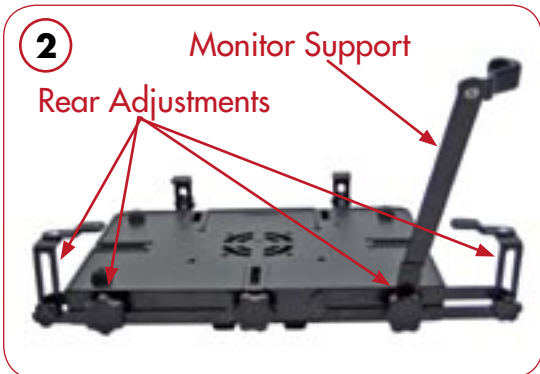

2 Next, install the monitor supports. Remove the knobs on the left and right of the deck near the back. Place the monitor support over the rear support bracket and re-install the knob. Do not tighten the knobs all the way. Repeat on opposite side.



3 Continue by opening the laptop up and setting it in place. Adjust the monitor support brackets so that they fit against the sides of the monitor.

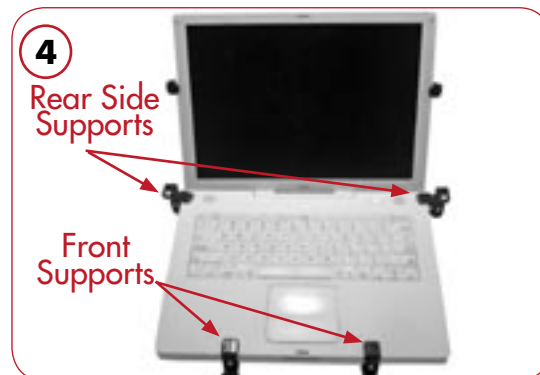

4 Set the width of the rear side supports, and tighten the knobs towards the back of the deck until secure. Adjust the front supports so that they are secure against the laptop. Tighten the knobs down. Place the handle in the location on the bottom of the deck. Do not tighten the handle down all the way.

5 Next remove the laptop. To do so fold the monitor supports down to the side, and spin the rear side supports outwards. Pick the laptop up in the rear and slide it out.



STAND ASSEMBLY AND SET UP



6 To begin the installation of the Mobotron stand you will need to determine what size bolts are used to fasten the passenger seat of your vehicle down. Remove the left front bolt (there may be a nut on a threaded stud also) with the correct size socket that you have pre-determined.



7 Choose the base set-up that will fit your vehicles seat arrangement the best. For best results try and get the stand mounting lug as vertical as possible. If you need to have the lug elevated use the threaded rod with the foot on it to support it. Place arrangement that you have chosen over the bolt hole (or stud) and tighten the fastener down tightly. **Note:** If you are using the adjustable foot lower it down so it is on the floor.



8 Next, take the stand assembly and place the base over the lug. Tighten the lower clamp around the lug. Place the laptop deck on the stand. Tighten the handle down on the bottom of the deck. Adjust the multiple pivot points to position the deck how you desire. Tighten all the pivot points and clamps down. Place your laptop back in the stand and make any final adjustments if needed.

Note: If your vehicle does not have a bolt or a stud easily accessible you can also use our Universal Floor Mount part #LTM-FM-101. If you would like an additional cross brace you can use our Telescoping Support Brace part #LTM-SA-102. (For both of these items see the pictures below.)

OPTIONAL ACCESSORIES (INSTALLED)



(Shown with Telescoping Support Brace Part #LTM-SA-102)



(Shown with Universal Floor Mount Part #LTM-FM-101)

© Bracketron Inc, 2007 All rights reserved.

The information in this document is subject to change without notice. Bracketron Inc. assumes no responsibility for any errors that may appear in this document nor do we assume any liability in connection with its use. This supersedes and voids all previous literature. Please contact the sales department for additional information. Bracketron Inc will not be responsible or liable for damage to vehicles in the installation and or removal of this Mobotron Universal Quick Release Laptop Stand. Bracketron Inc will not be liable for personal injuries or damage to property resulting from a motor vehicle accident and or improper installation of this Bracketron Inc mount.



Bracketron Inc 5249 West 73rd Street, Suite G, Edina, MN 55439
tel: 952-746-7775 fax: 1-800-660-1784 toll free: 1-866-237-4443
email: sales@bracketron.com web: www.bracketron.com

OPTIONAL ACCESSORIES



Telescoping Support Brace
Part #**LTM-SA-102**

Mobotron's Telescoping Support Brace provides added stability and support for our LTM-MS-525 Universal Vehicle Laptop Mount when needed. The brace can be mounted several different ways, either to another seat bolt or to any hard stable surface using a 3M Dual Lock Fastener. More than one brace can be used with the LTM-MS-525 if desired. The brace utilizes an easy "Twist Lock Mechanism" to lock the telescoping tubes in place after installation. The LTM-SA-102 is easy to install and is a great additional accessory to the popular Vehicle Laptop Mount.



Universal Floor Mount
Part #**LTM-FM-101**

The Universal Floor Mount is the ideal solution for mounting your Mobotron Laptop Mount when the underseat bolts are not accessible. Featuring the same easy-on/easy-off design, the black powder-coated Universal Floor Mount can be mounted anywhere using the six (6) included sheet-metal screws.



Adjustable C-Clamp
Part #**LTM-CC-105**

The Adjustable C-Clamp allows you to take your Mobotron Laptop mount out of vehicle and into the home or office to perform double duty. The unique two piece design fits together and offers four (4) different positions to accommodate various tabletop thicknesses. The large T-knob screw makes for easy tightening and securing the clamp to the tabletop. The C-Clamp is designed to work with the LTM-MS-525 Universal Vehicle Laptop Mount for mounting computer LCD monitors in a office environment.



Shown as a monitor holder
with Adjustable C-Clamp
Part #**LTM-CC-105**

The pictures on the left show the LTM-MS-525 Pan Head Deck with its built in industry standard VESA compatible mounting bracket. Attaching an LCD monitor is as easy as unscrewing four thumb screws and removing the VESA mounting bracket from the deck. Simply attach the bracket to the computer monitor then attach the post the C-Clamp. You now have a instant monitor stand for your desk or display.